

EXPRESSÃO GRÁFICA

AXONOMETRIA ORTOGONAL



PERSPECTIVAS

Perspectiva é uma forma de representar graficamente objetos tridimensionais através de uma única projeção.



PERSPECTIVAS

Ela pode ser feita de várias maneiras, com resultados diferentes, que se assemelham mais ou menos à visão humana

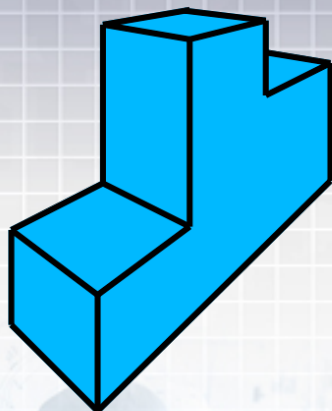

CÔNICA

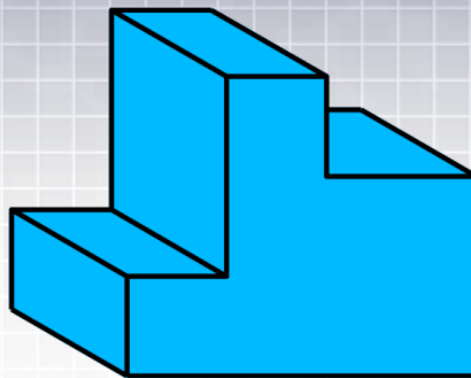

CAVALEIRA

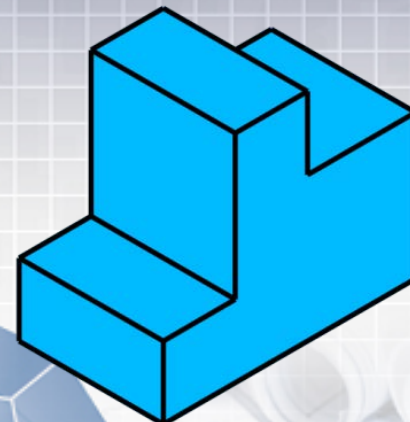

AXONOMETRIA

AXONOMETRIA

- Utiliza a projeção **Cilíndrica Ortogonal**.
- Permite fazer medições no desenho, mas só, para arestas paralelas aos eixos.
- Deforma o objeto, mas é mais simples de visualizar que as vistas ortogonais.



AXONOMETRIA

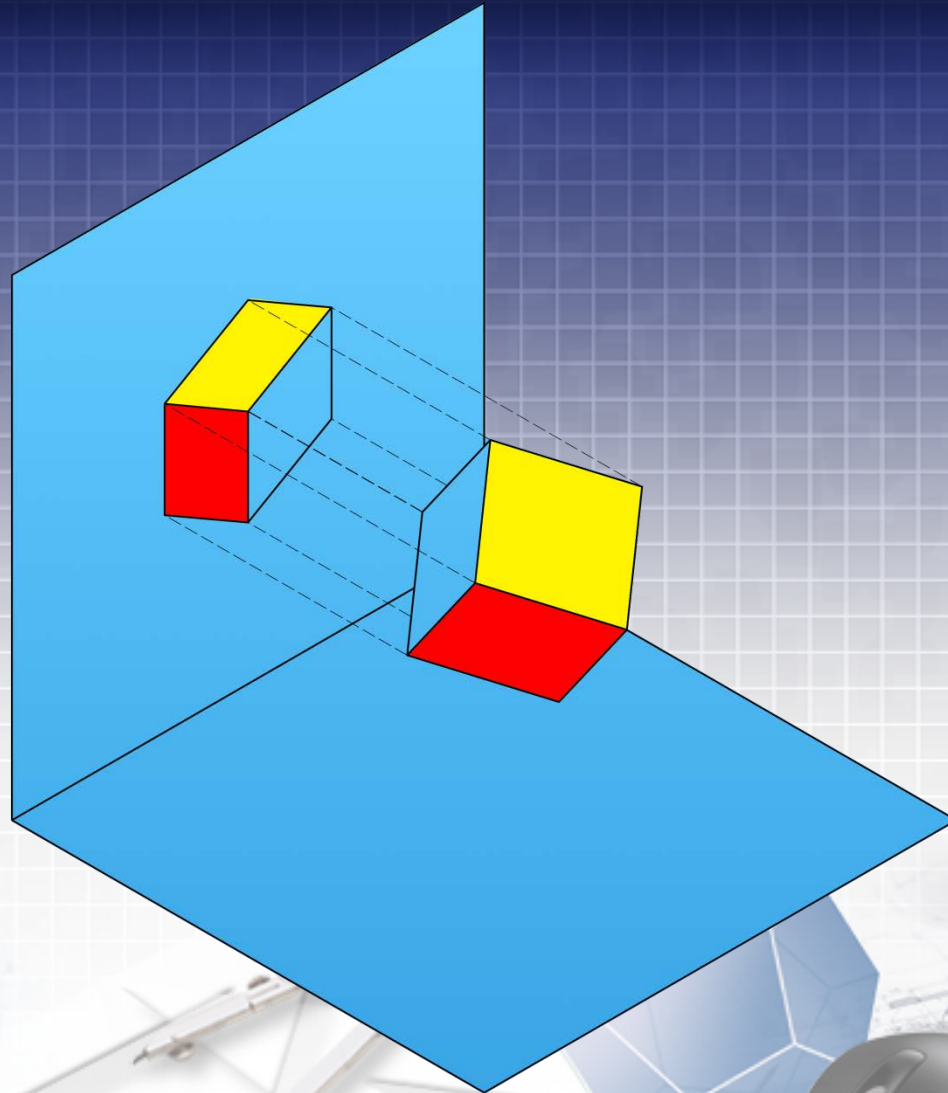

AXONOMETRIA

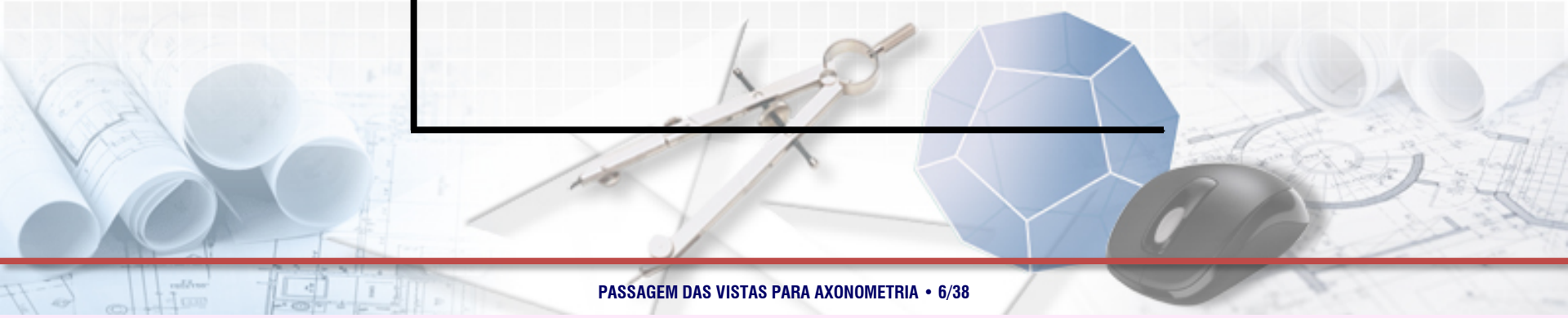
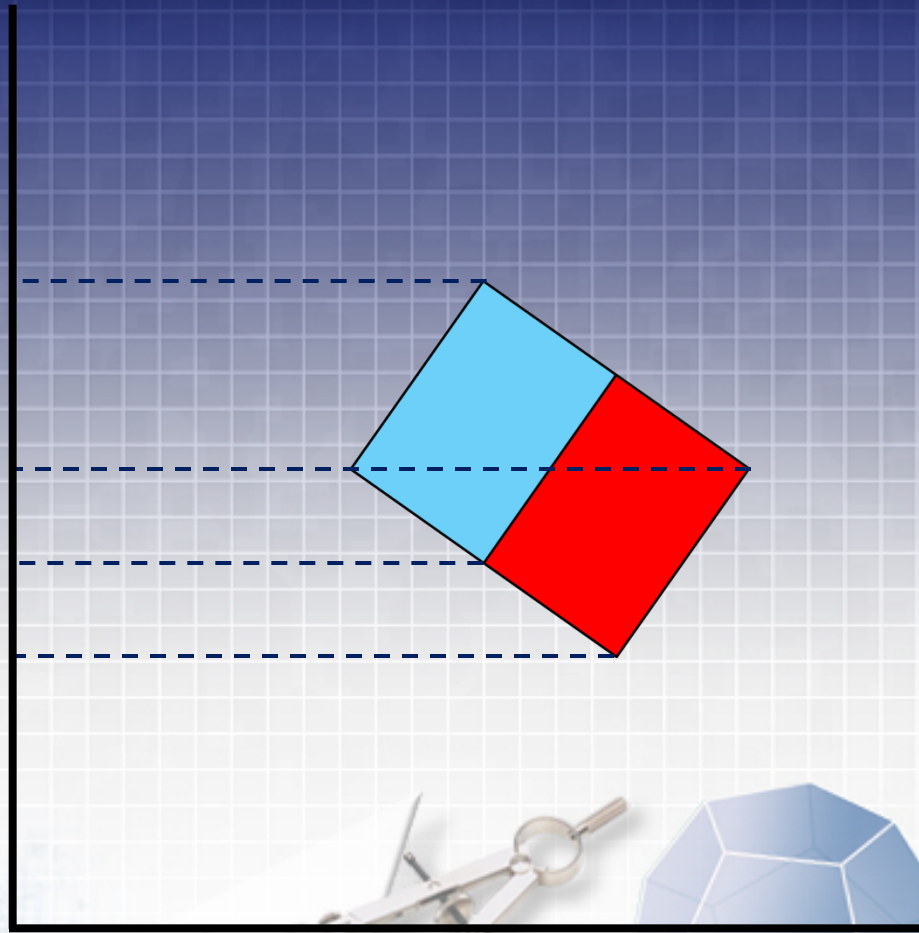

AXONOMETRIA

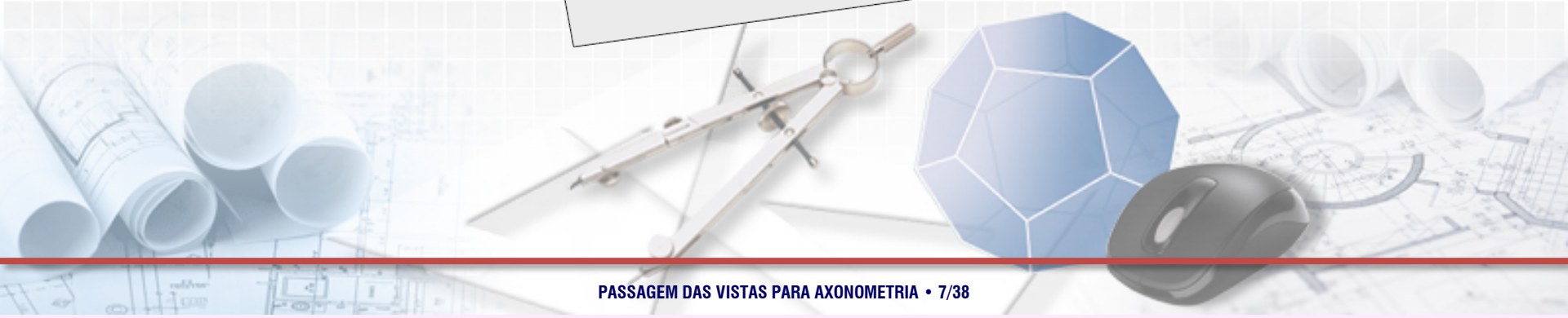
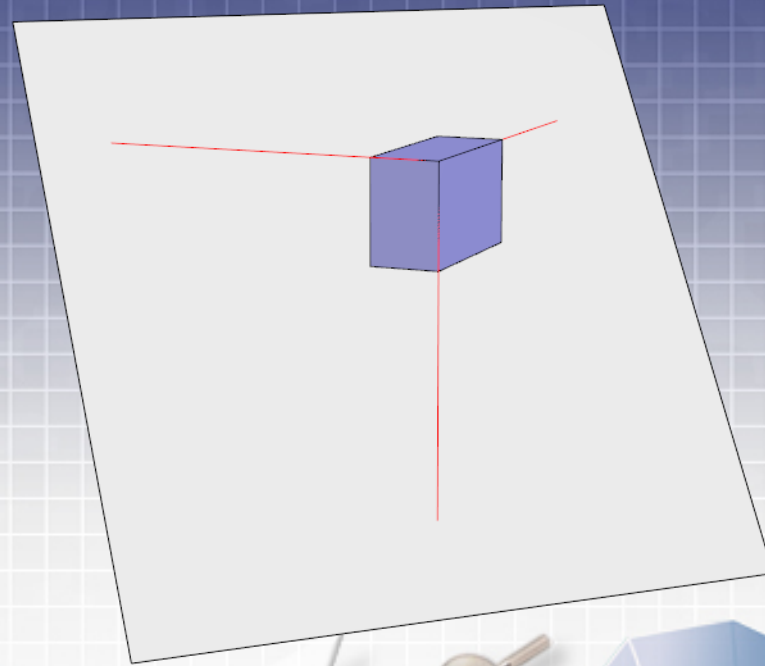

AXONOMETRIA

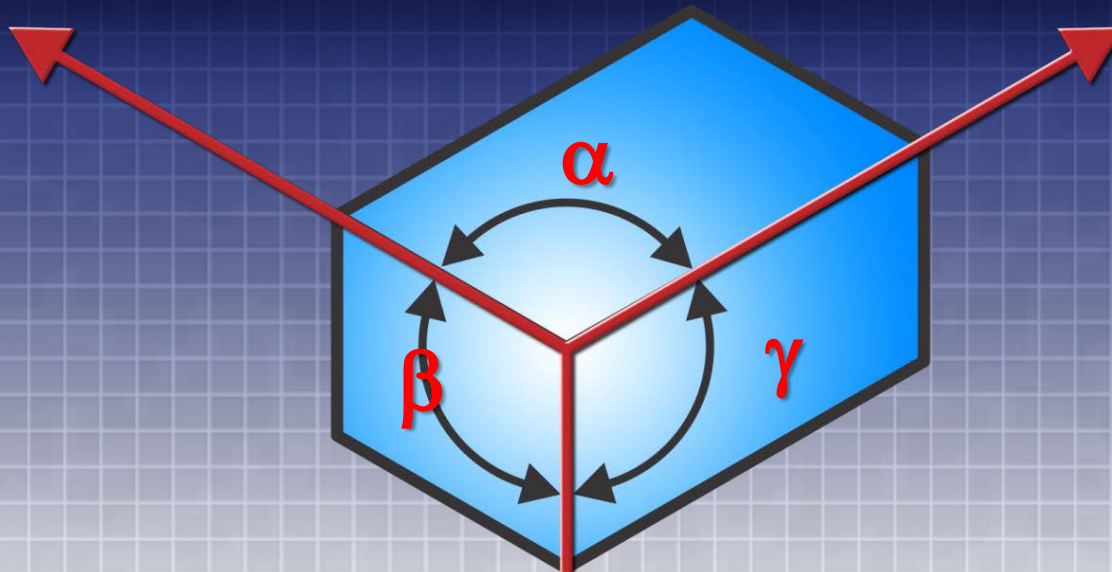

ISOMETRIA

$$\alpha = \beta = \gamma$$

DIMETRIA

$$\alpha = \gamma \neq \beta$$

TRIMETRIA

$$\alpha \neq \beta \neq \gamma$$

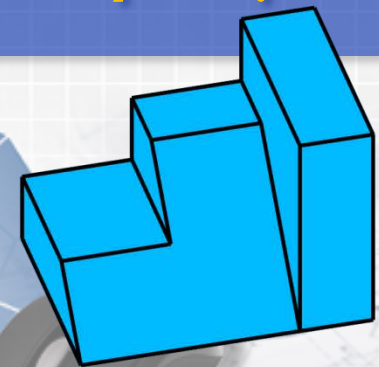
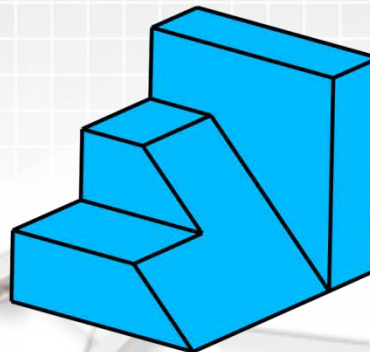
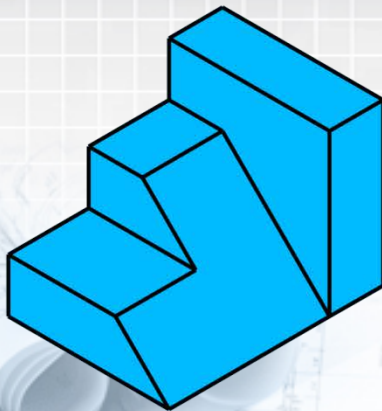

ISOMÉTRICA

- **Perspectiva Isométrica Real ou Exata**
- **Coeficiente de redução é 0,816**
- **Na cotagem as dimensões são reais.**



ISOMÉTRICA

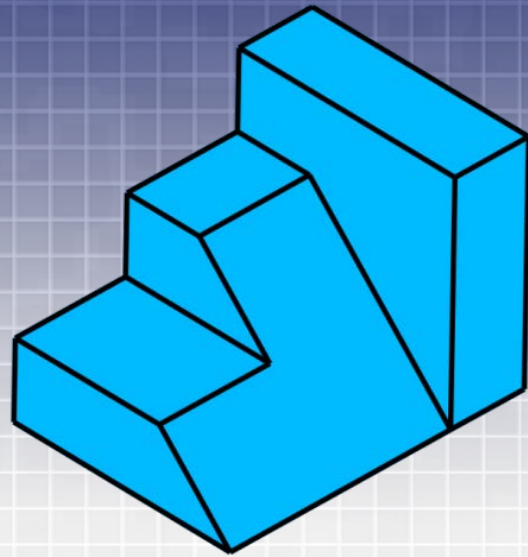

**REAL
(COM REDUÇÃO)**

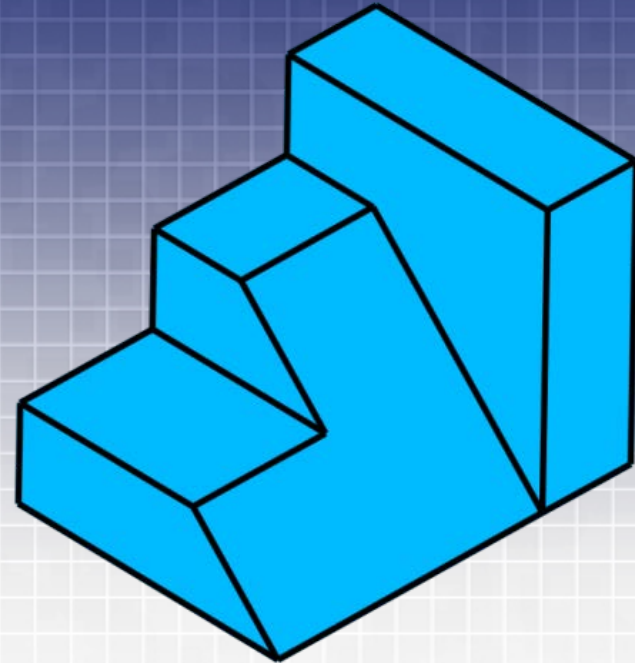

**SIMPLIFICADA
(SEM REDUÇÃO)**

DIMÉTRICA

Ângulo a	Ângulo b	Eixo A	Eixo B	Eixo C
7°	42°	1	1	0,5
10° 22'	39° 49'	1	1	0,6
14° 10'	37° 55'	1	1	0,7
18° 40'	35° 40'	1	1	0,7

TRIMÉTRICA

Ângulo a	Ângulo b	Eixo A	Eixo B	Eixo C
5° 10'	17° 50'	1	0,9	0,5
9° 50'	24° 30'	1	0,9	0,6
14° 30'	26° 40'	1	0,9	0,7
11° 50'	16°	1	0,9	0,7

EXPRESSÃO GRÁFICA

PASSAGEM DAS VISTAS PARA AXONOMETRIA

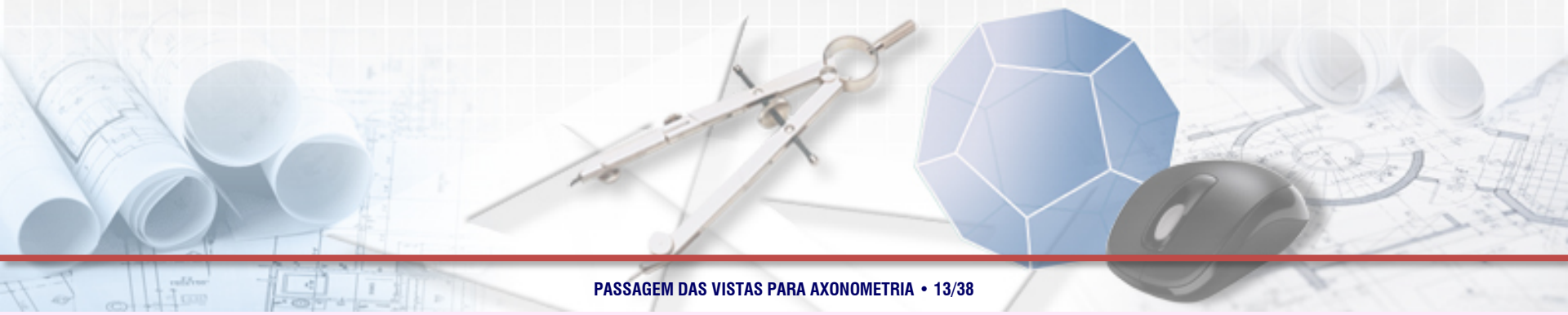

PASSAGEM DAS VISTAS ORTOGRÁFICAS PARA AXONOMETRIA

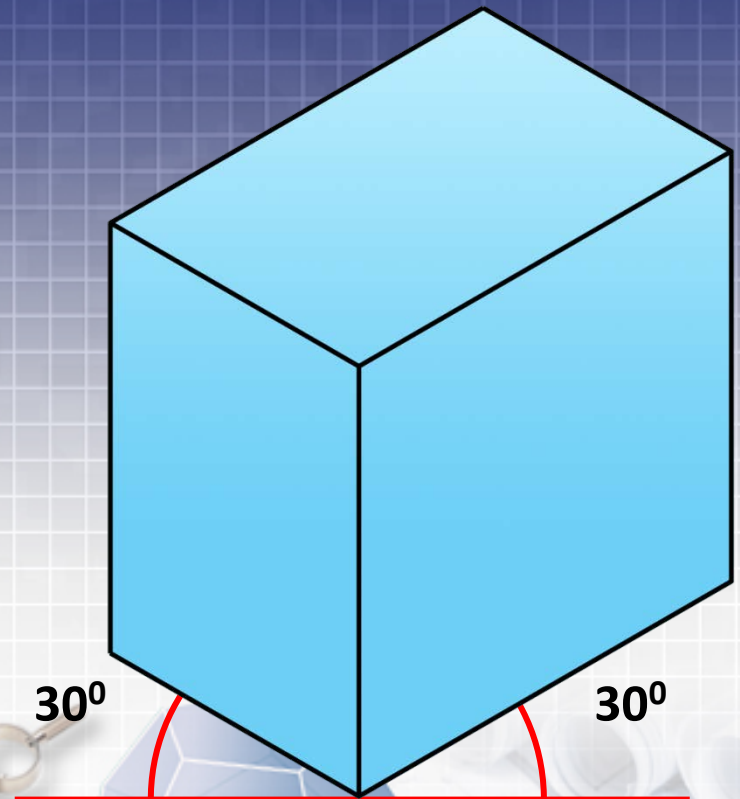
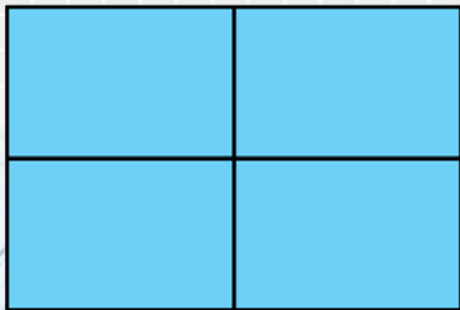
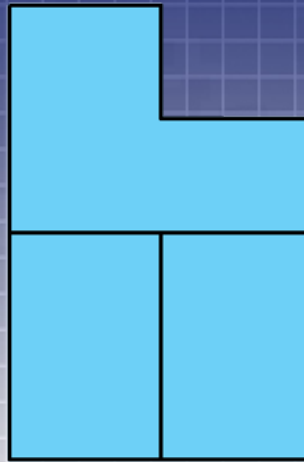
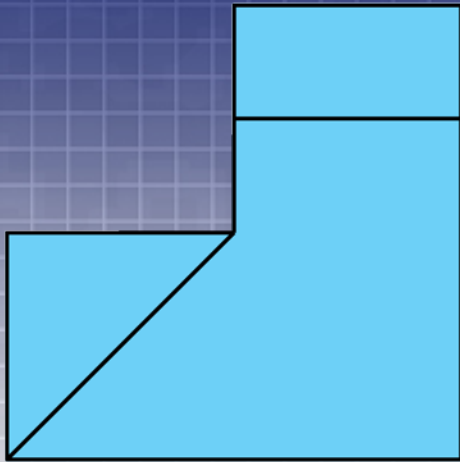

PASSAGEM DAS VISTAS ORTOGRÁFICAS PARA AXONOMETRIA

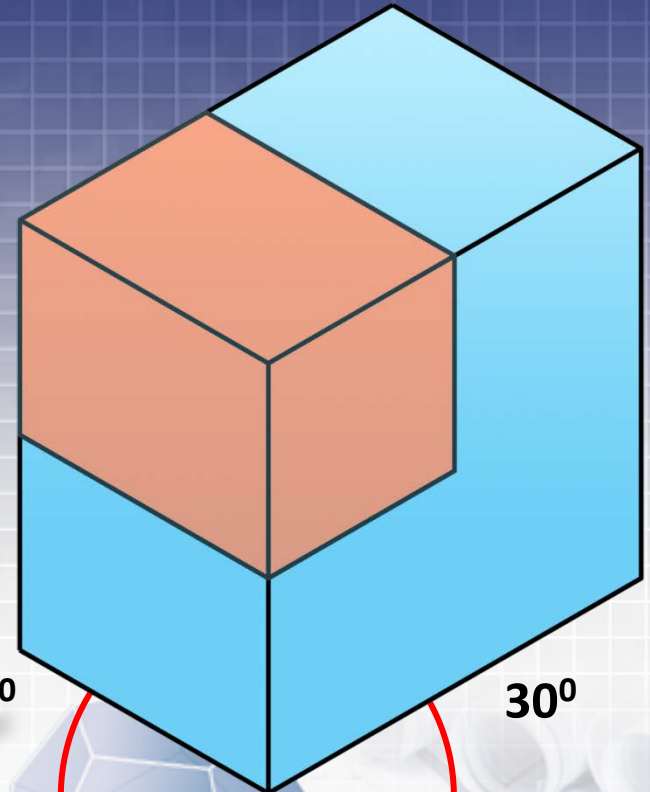
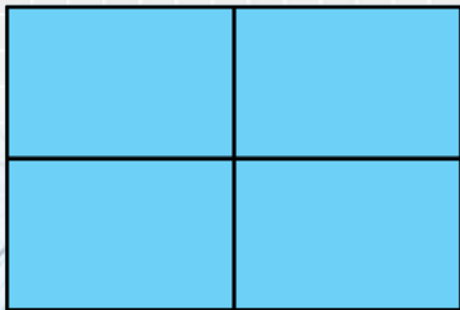
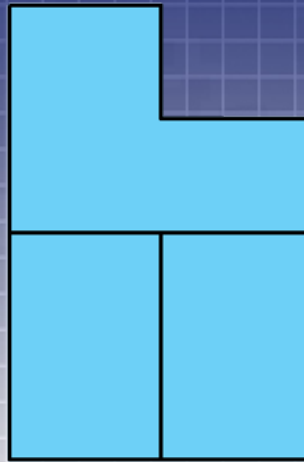
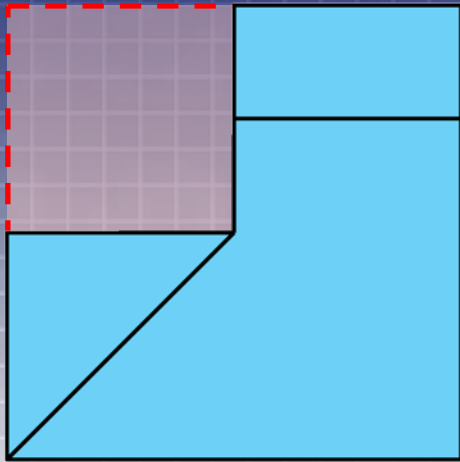

PASSAGEM DAS VISTAS ORTOGRÁFICAS PARA AXONOMETRIA

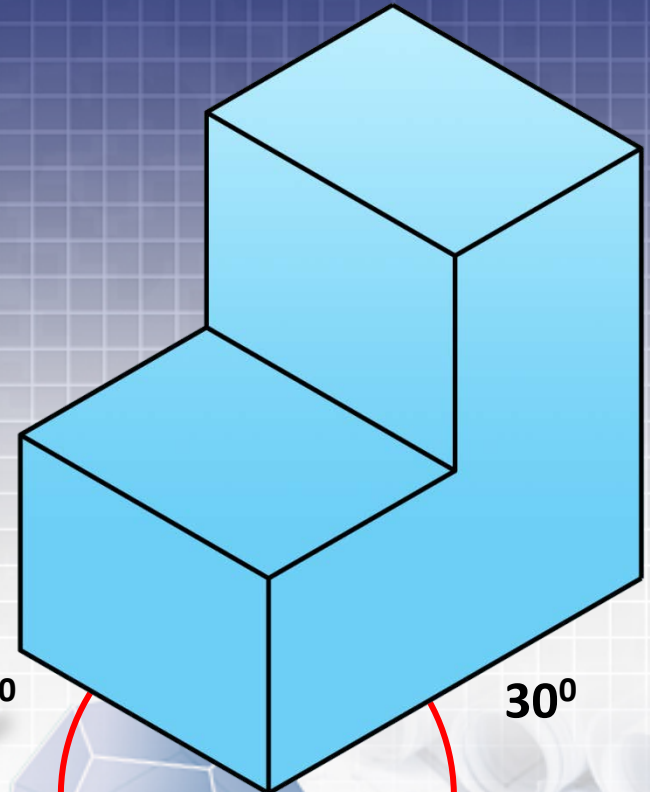
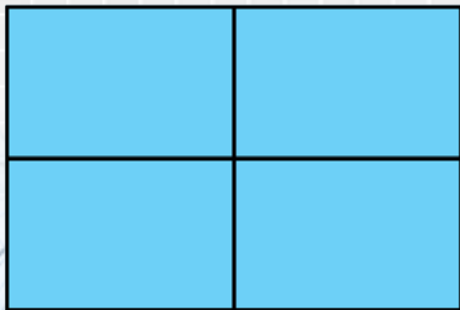
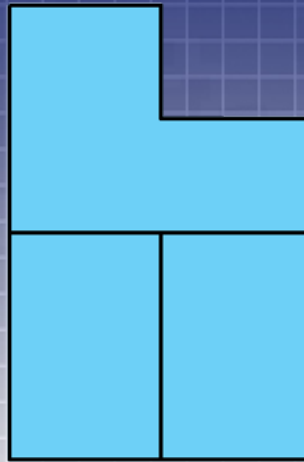
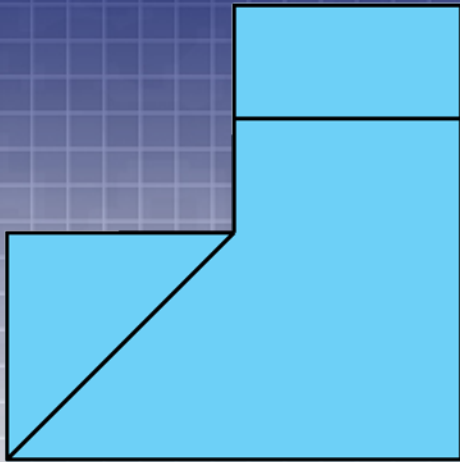

PASSAGEM DAS VISTAS ORTOGRÁFICAS PARA AXONOMETRIA

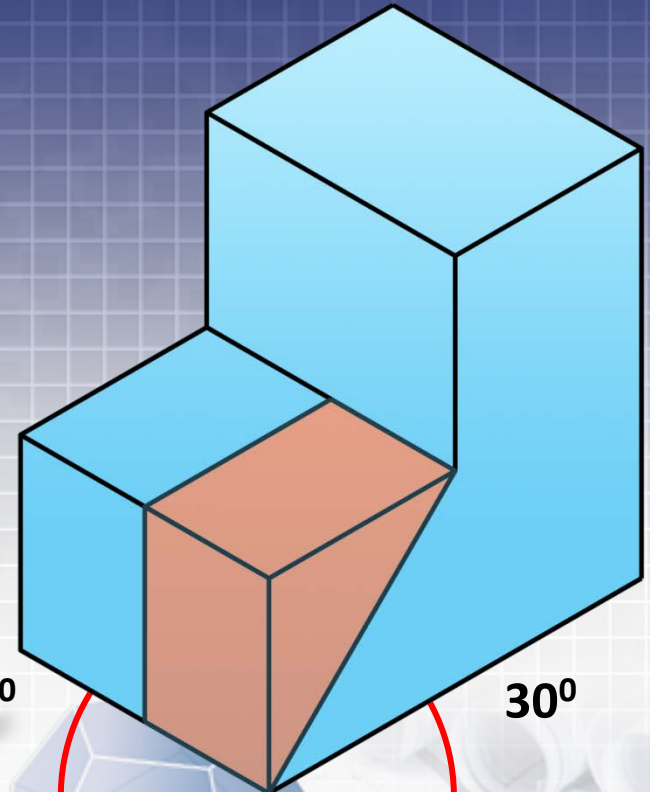
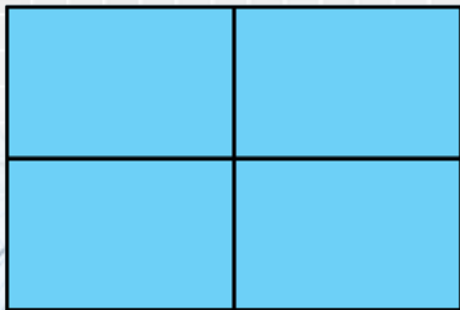
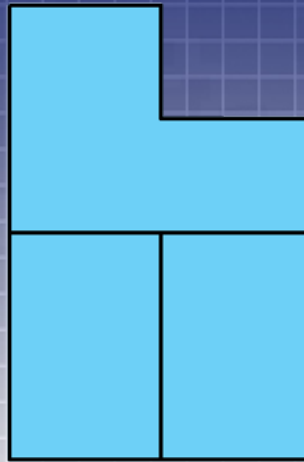
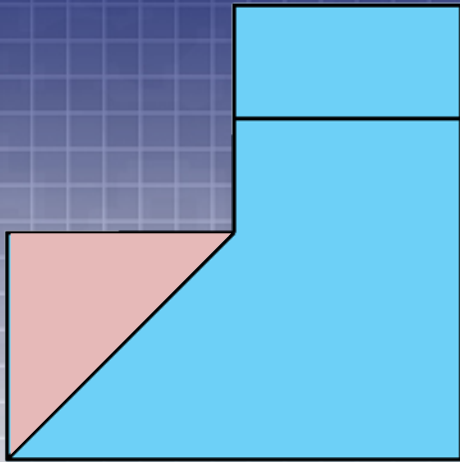

PASSAGEM DAS VISTAS ORTOGRÁFICAS PARA AXONOMETRIA

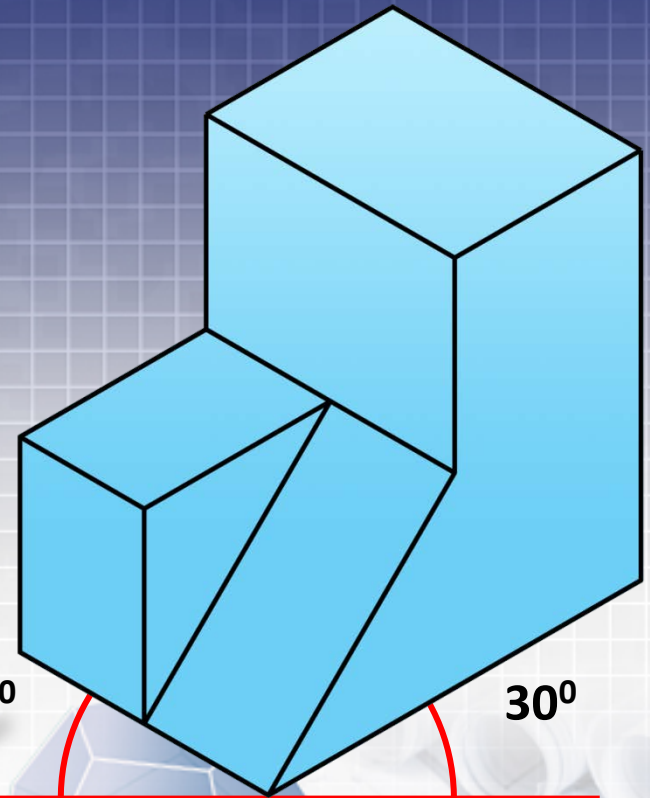
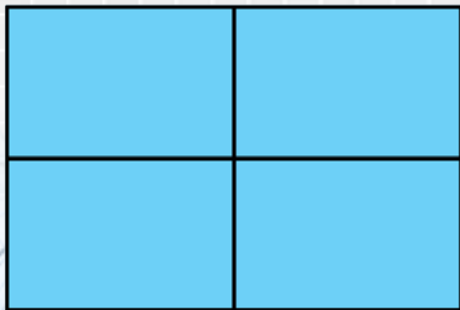
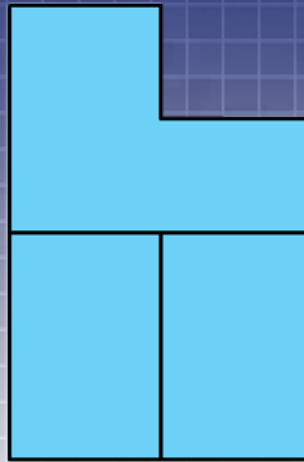
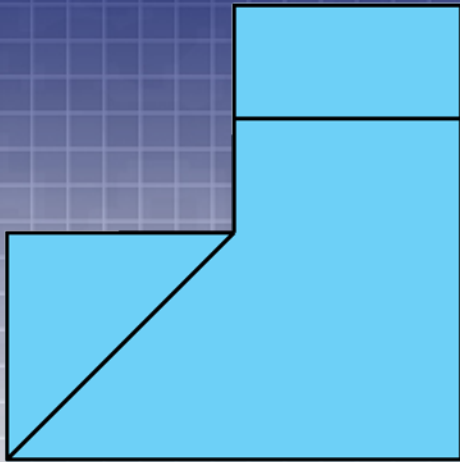

PASSAGEM DAS VISTAS ORTOGRÁFICAS PARA AXONOMETRIA

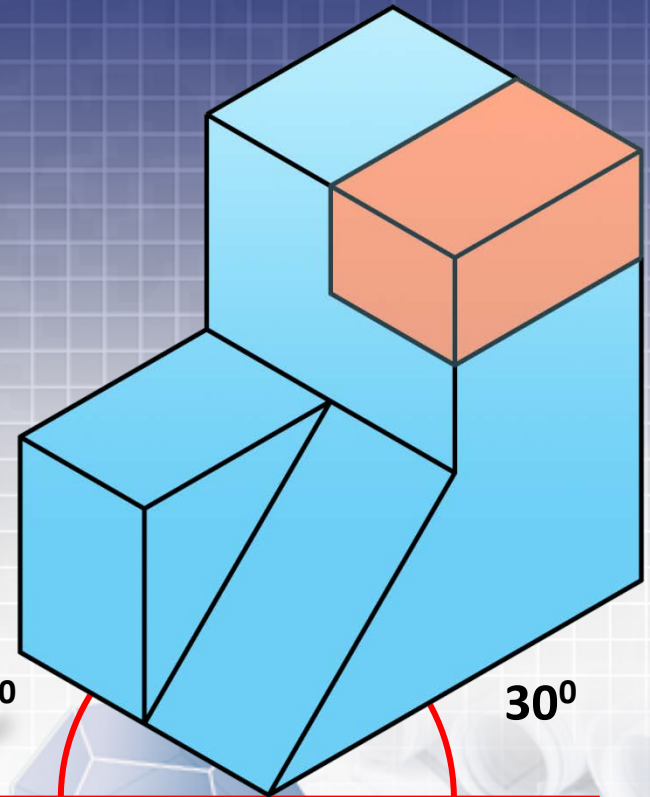
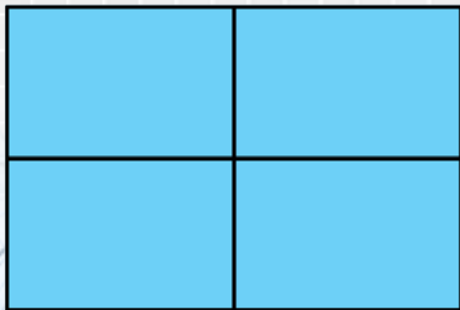
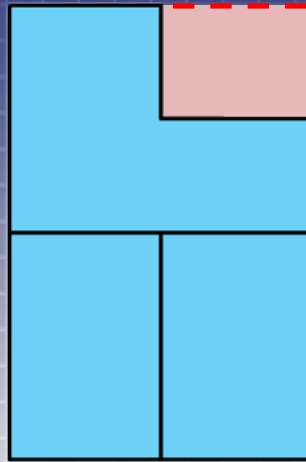
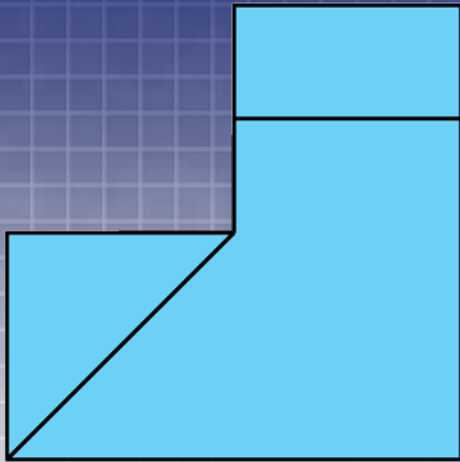

PASSAGEM DAS VISTAS ORTOGRÁFICAS PARA AXONOMETRIA

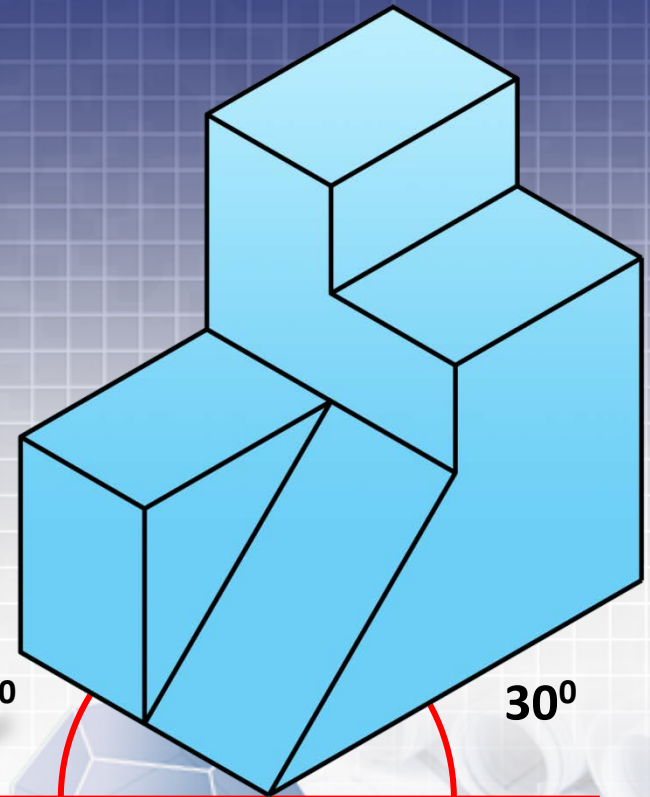
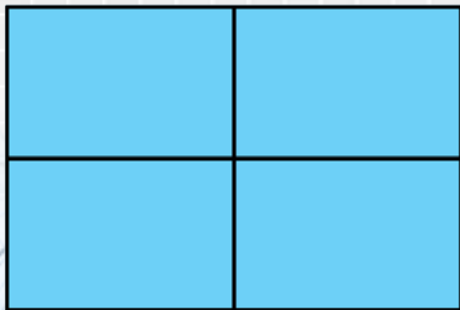
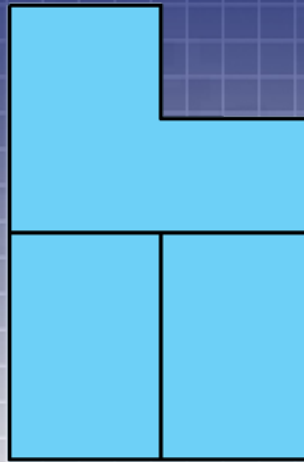
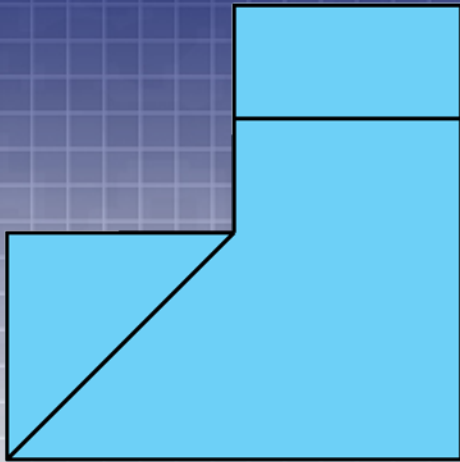

EXERCÍCIO

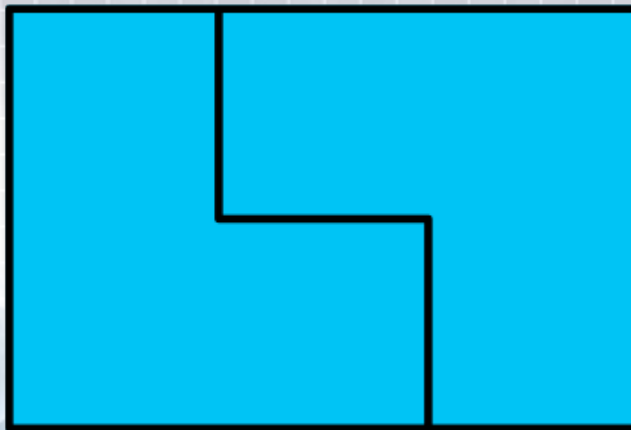
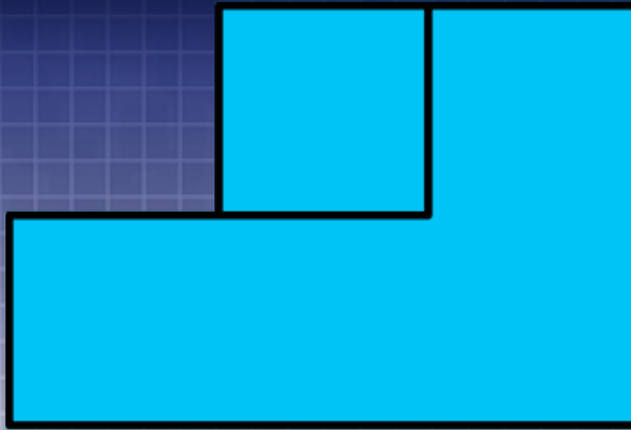

EXERCÍCIO

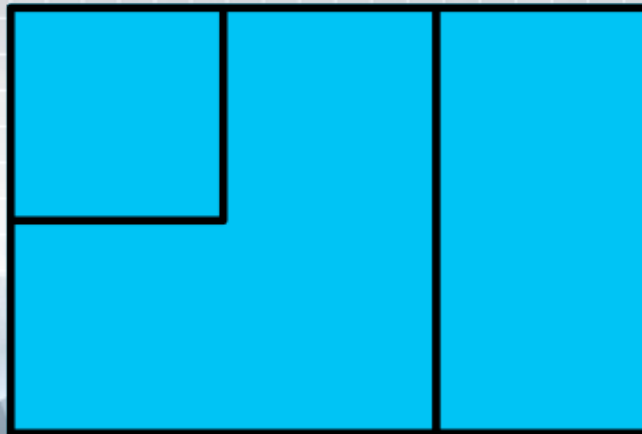
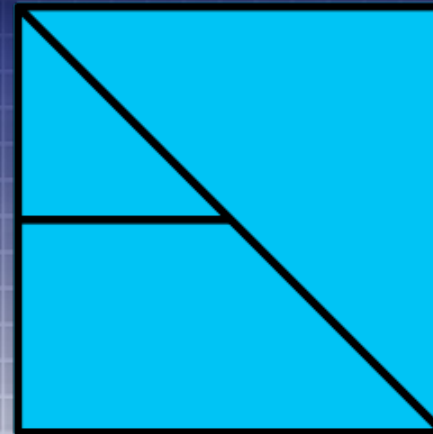
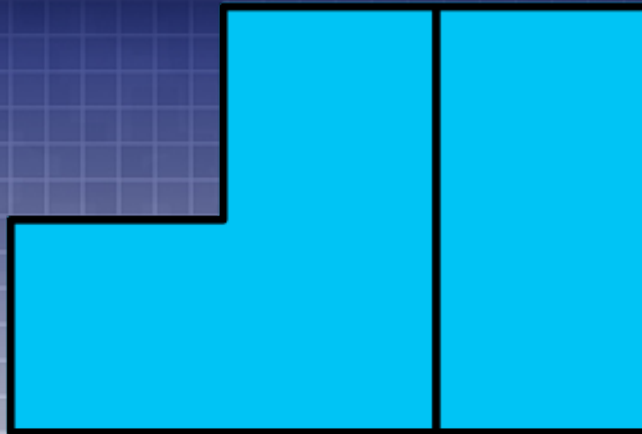

EXPRESSÃO GRÁFICA

CÍRCULO EM AXONOMETRIA

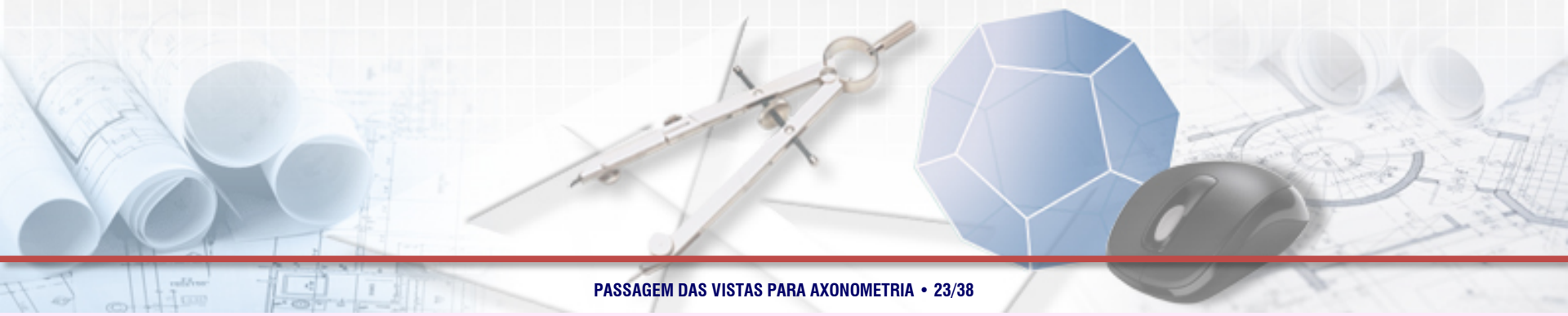

CÍRCULO EM AXONOMETRIA

A projeção ortogonal de um círculo cujo plano não é paralelo ao plano de projeção é sempre uma elipse



CÍRCULO EM AXONOMETRIA

Dispor um quadrado circunscrito a um círculo, devidamente projetado como um paralelogramo, os pontos de tangência da elipse (projeção) com os lados desse paralelogramo estão sempre nos pontos médios desses lados.

CÍRCULO EM AXONOMETRIA

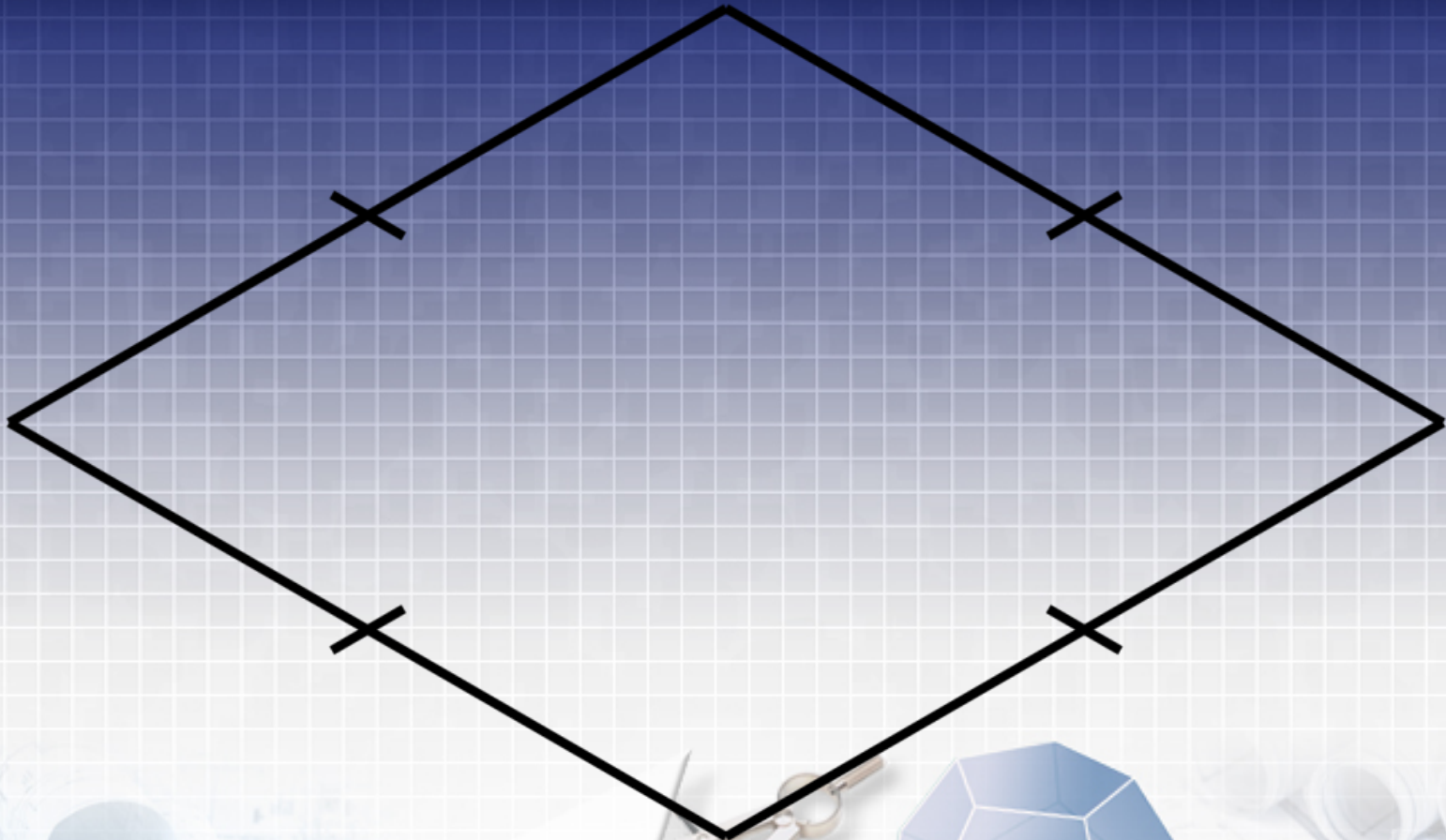

Quadrado em perspectiva isométrica

CÍRCULO EM AXONOMETRIA

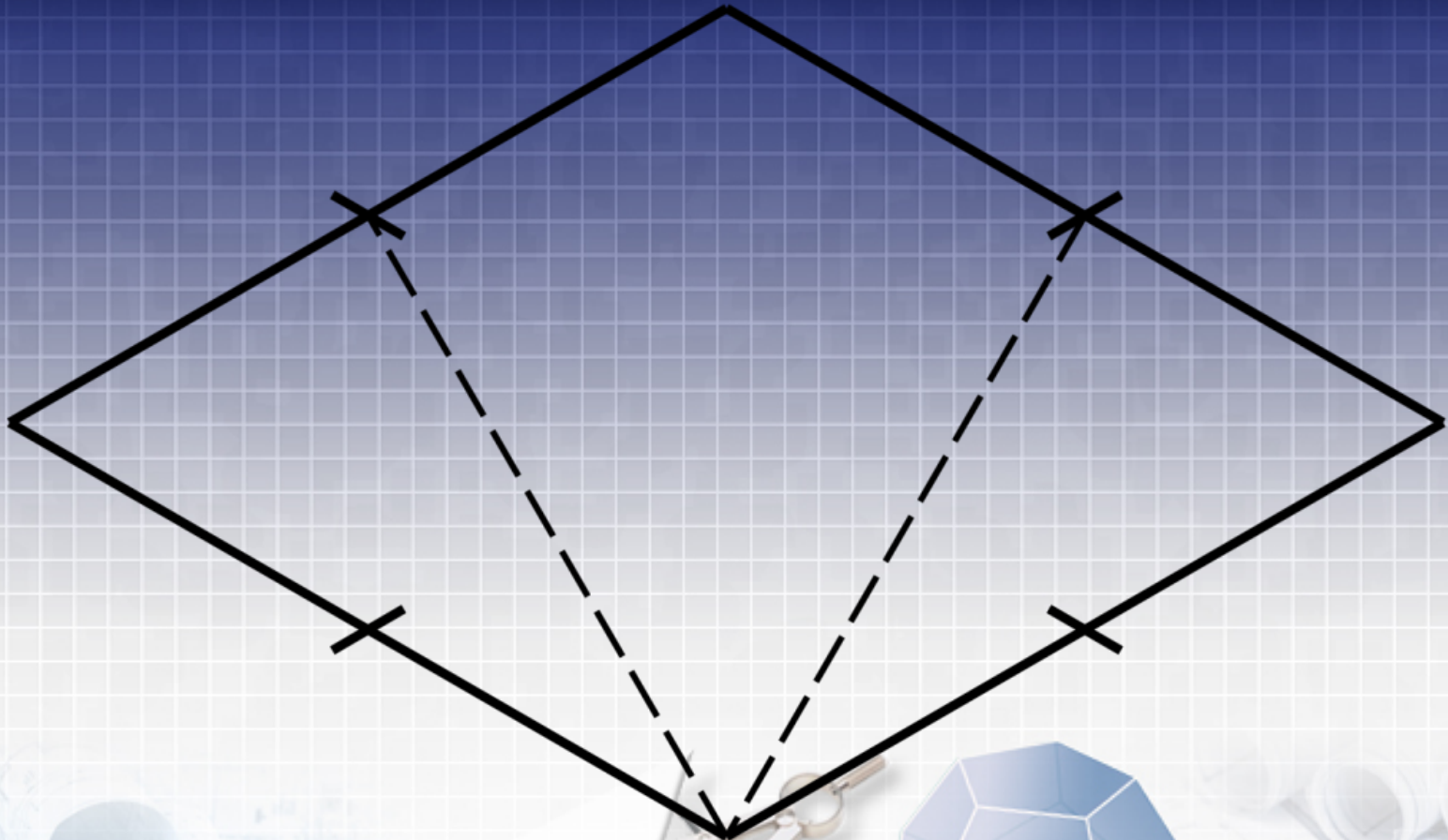

Medianas do vértice da diagonal menor

CÍRCULO EM AXONOMETRIA

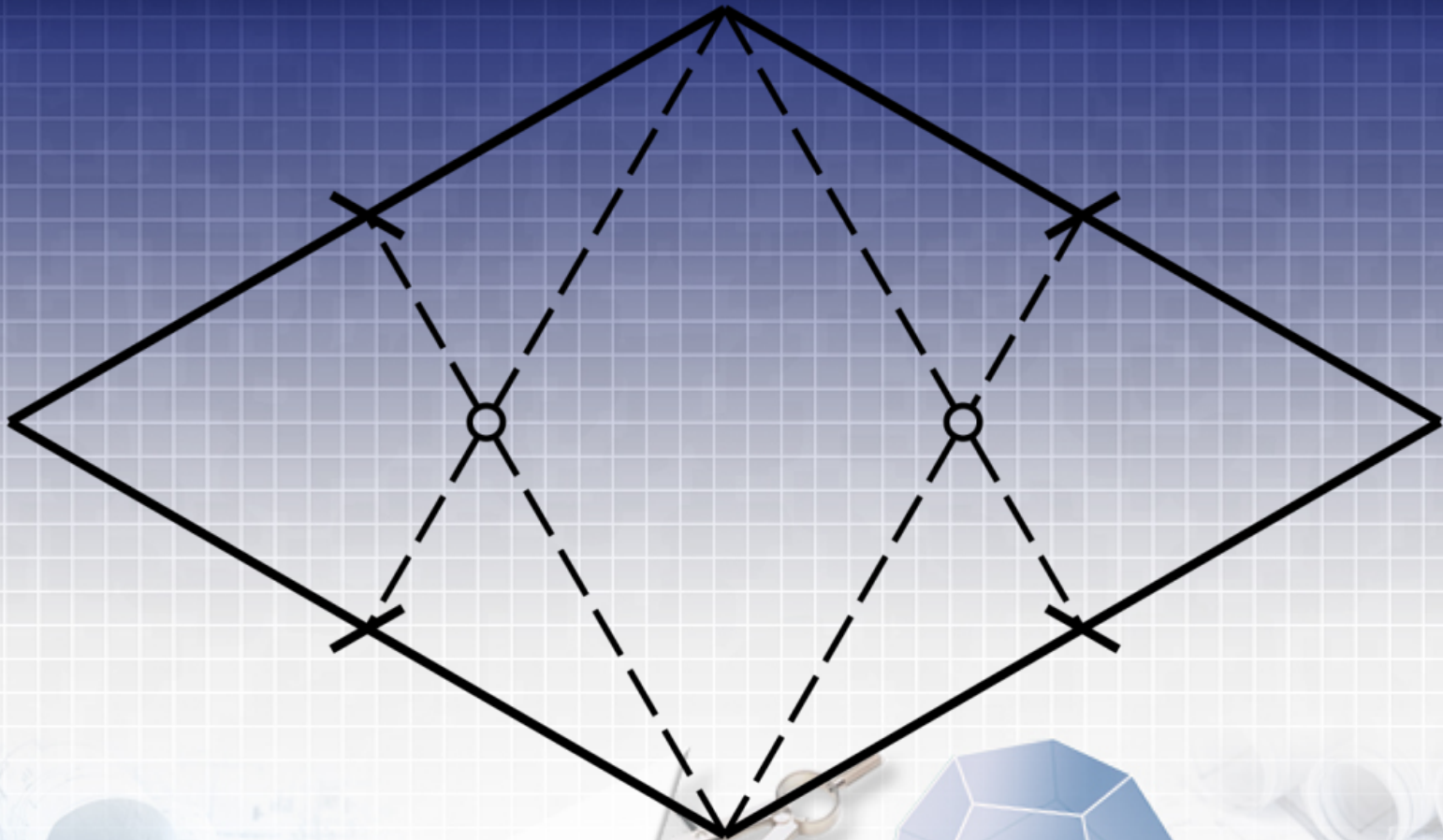

Medianas do vértice da diagonal menor

CÍRCULO EM AXONOMETRIA

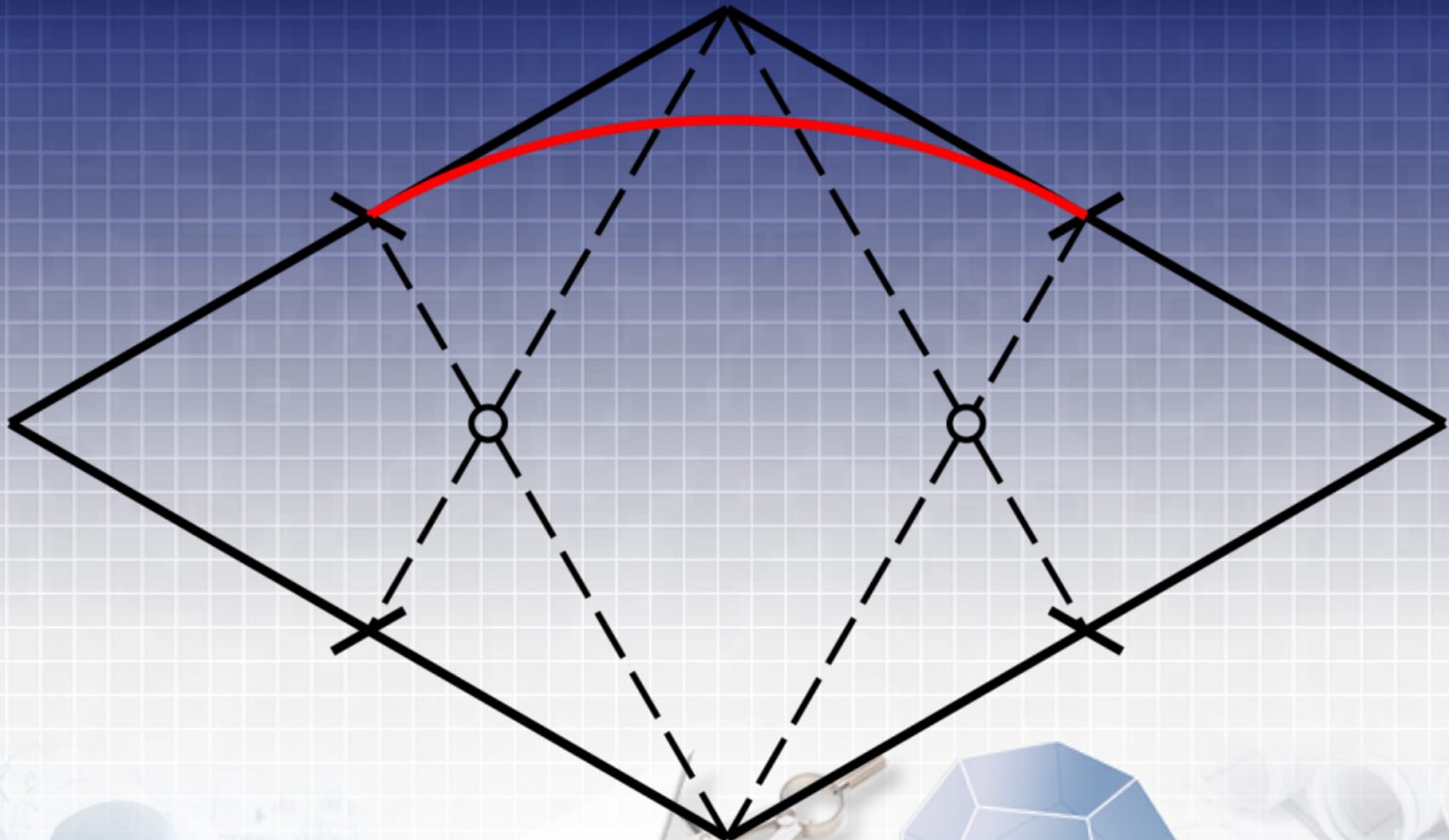

Centrar compasso no vértice da diagonal menor

CÍRCULO EM AXONOMETRIA

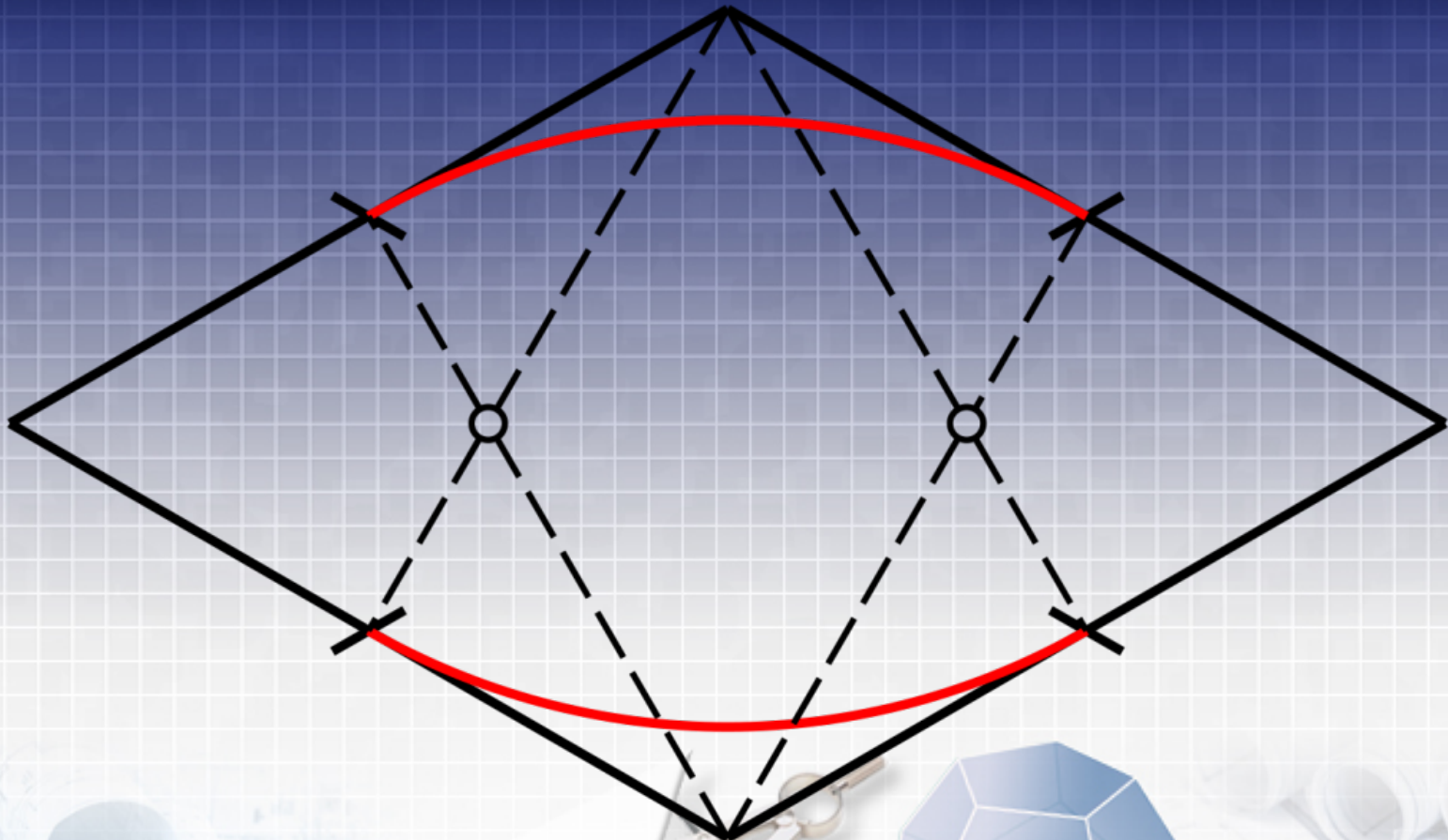

Medianas do vértice da diagonal menor

CÍRCULO EM AXONOMETRIA

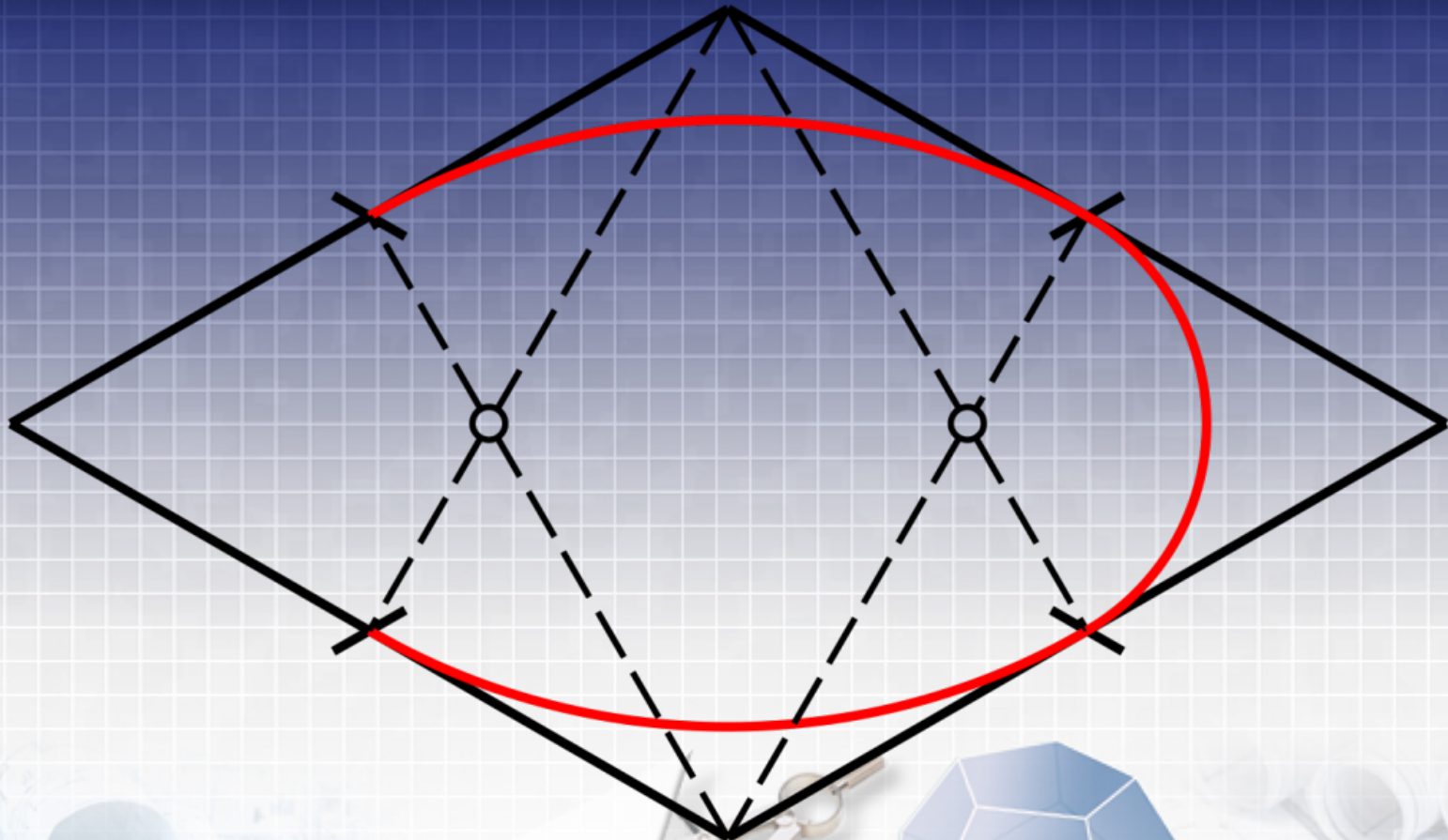

Centrar compasso no cruzamento das medianas

CÍRCULO EM AXONOMETRIA

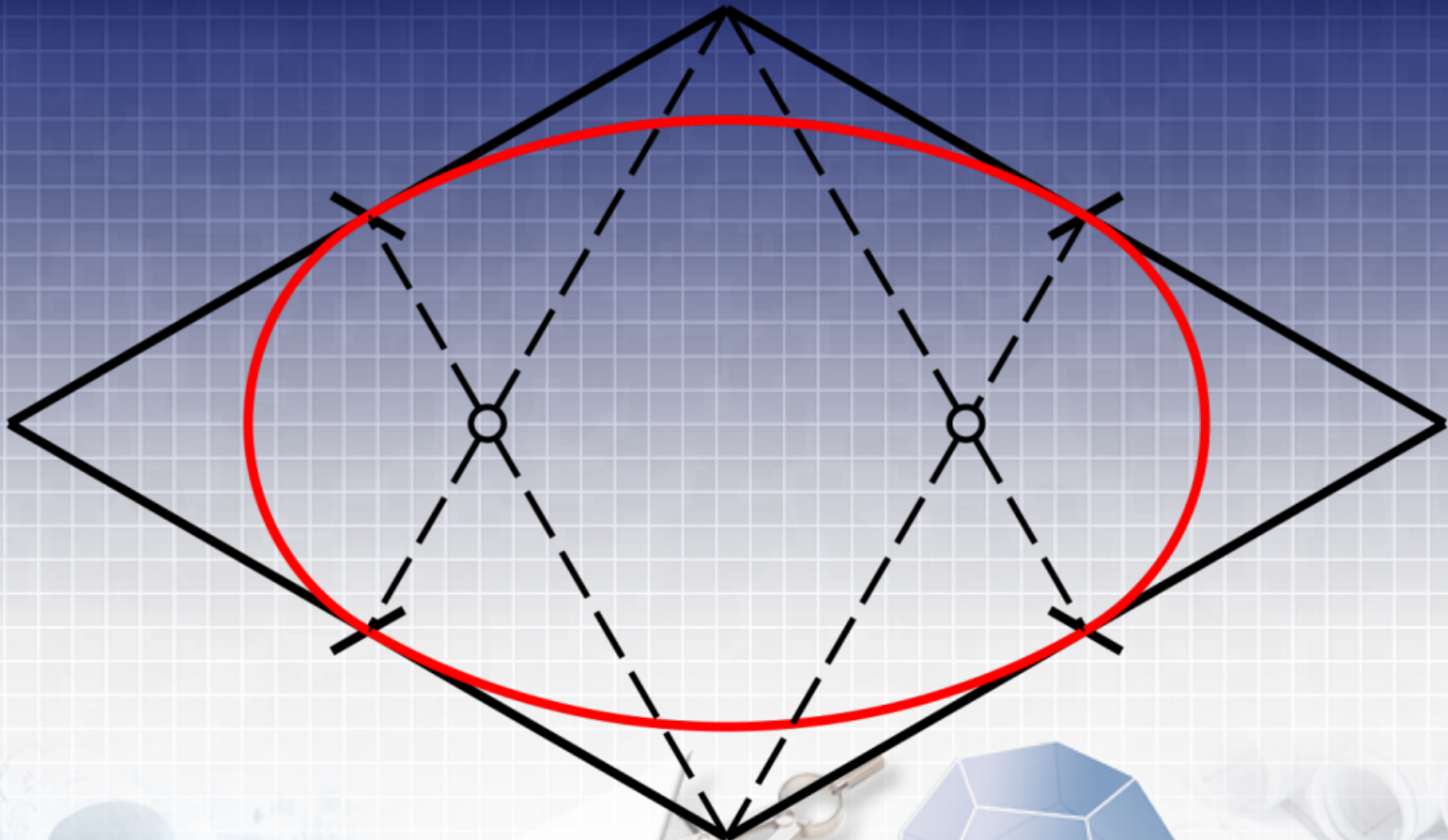

Centrar compasso no cruzamento das medianas

CÍRCULO EM AXONOMETRIA

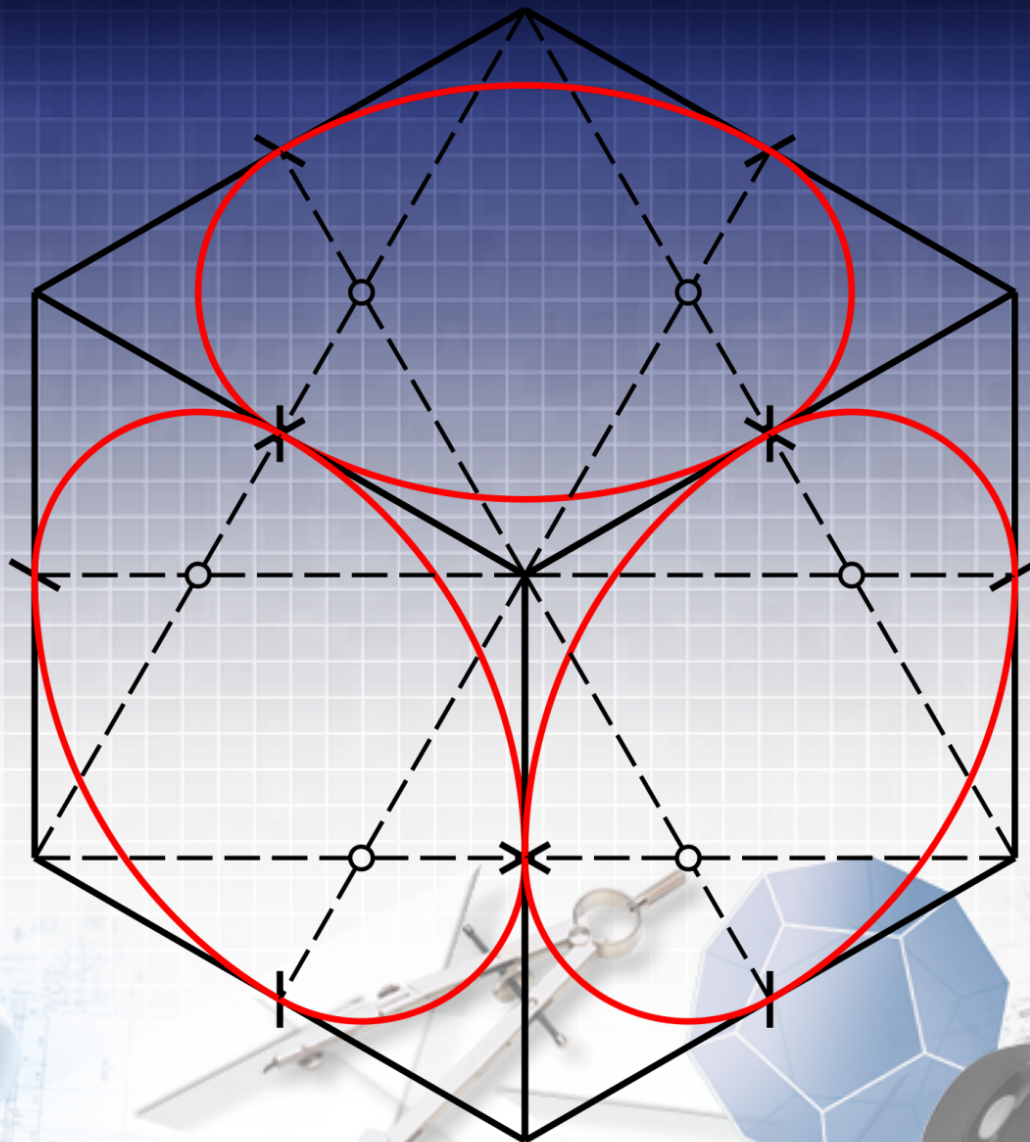

CÍRCULO EM AXONOMETRIA

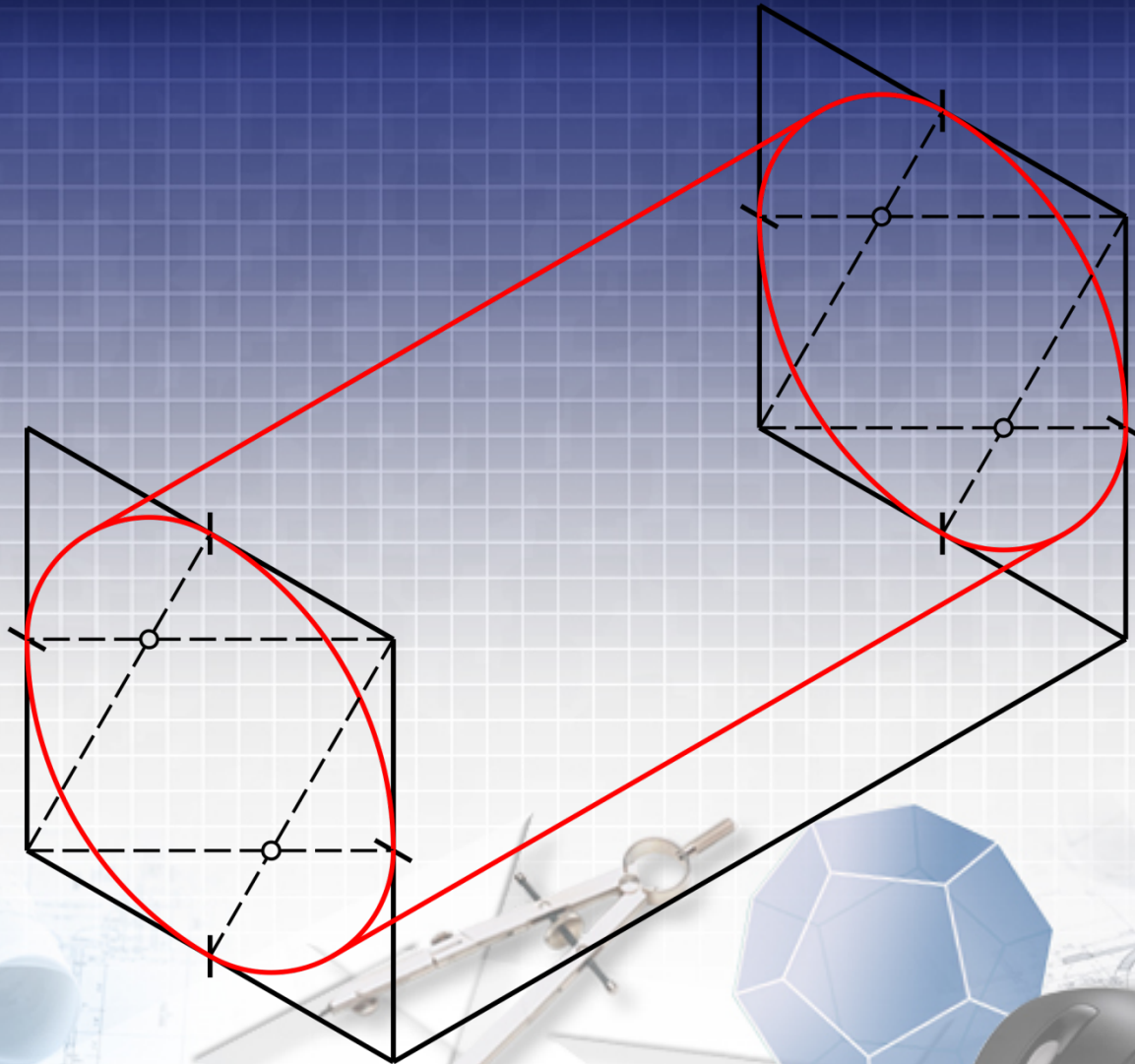

CÍRCULO EM AXONOMETRIA

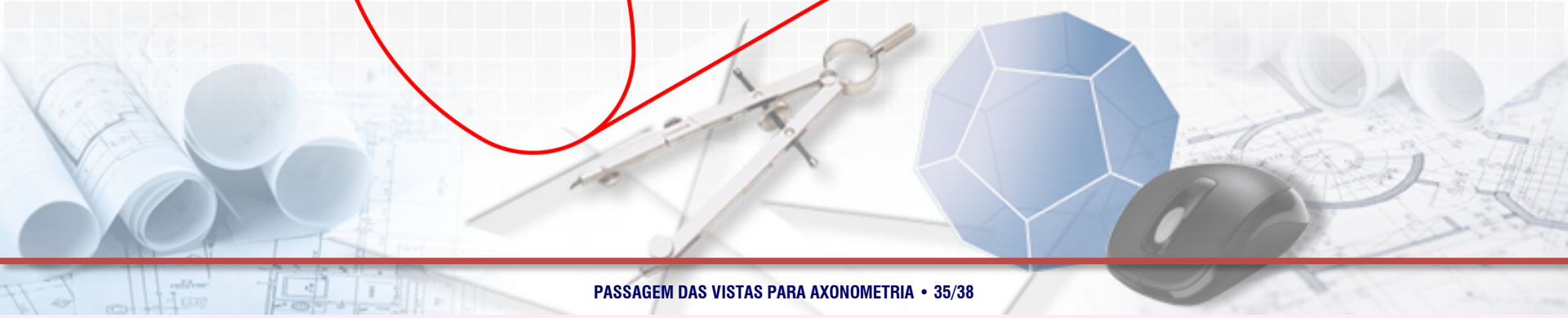
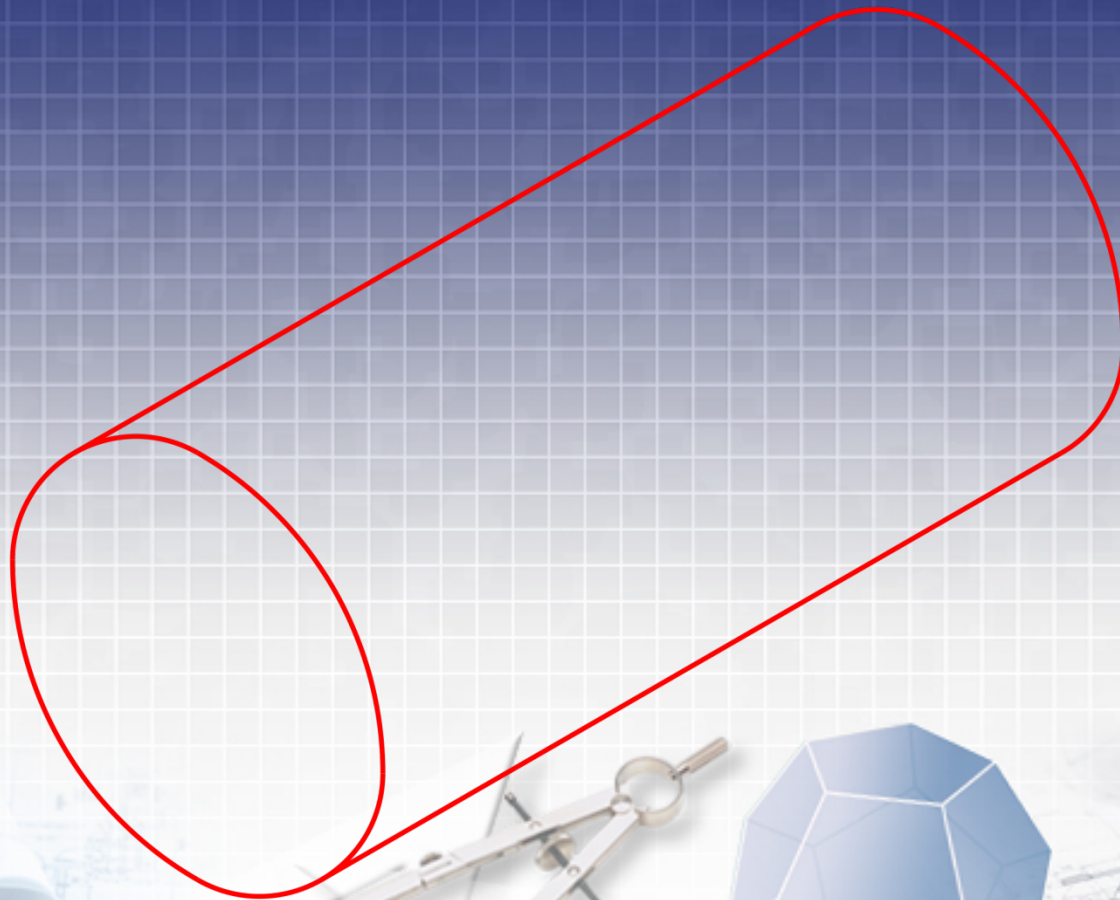

EXPRESSÃO GRÁFICA

CURVAS IRREGULARES EM AXONOMETRIA

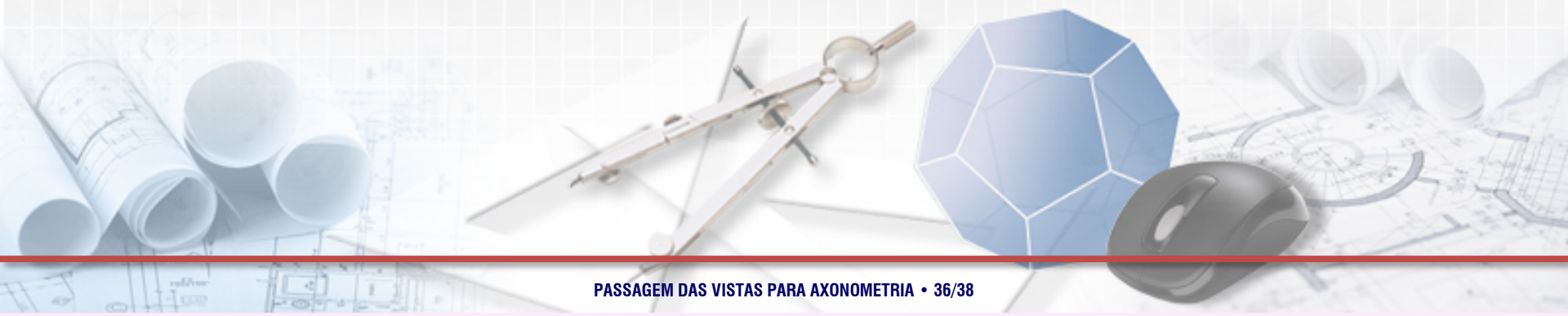

CURVAS IRREGULARES EM AXONOMETRIA

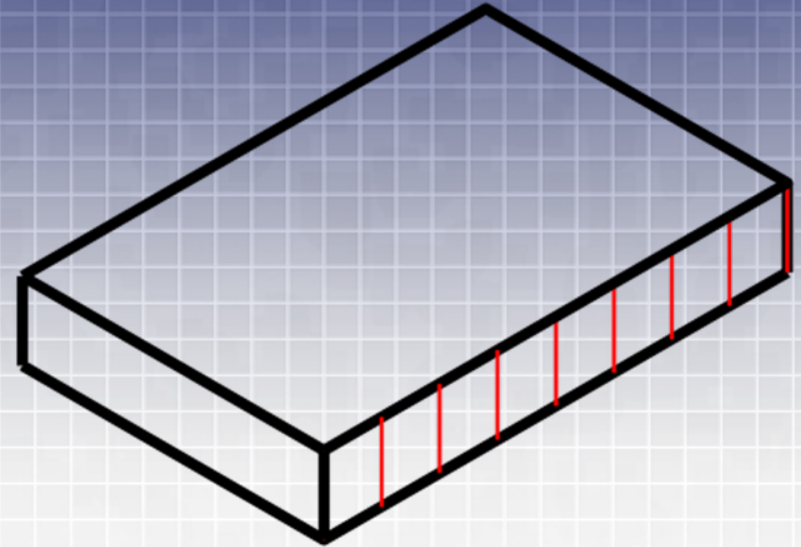
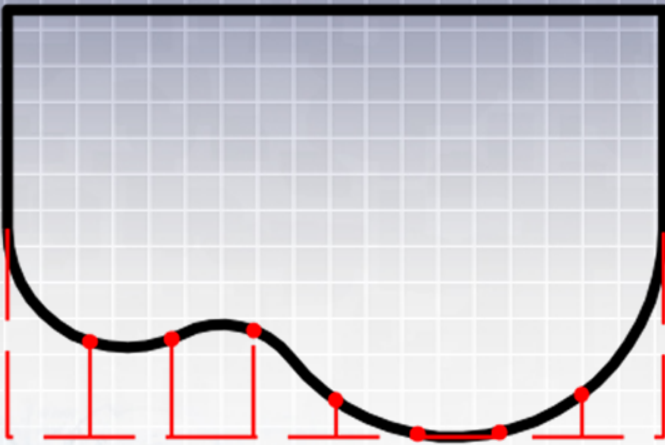

CURVAS IRREGULARES EM AXONOMETRIA

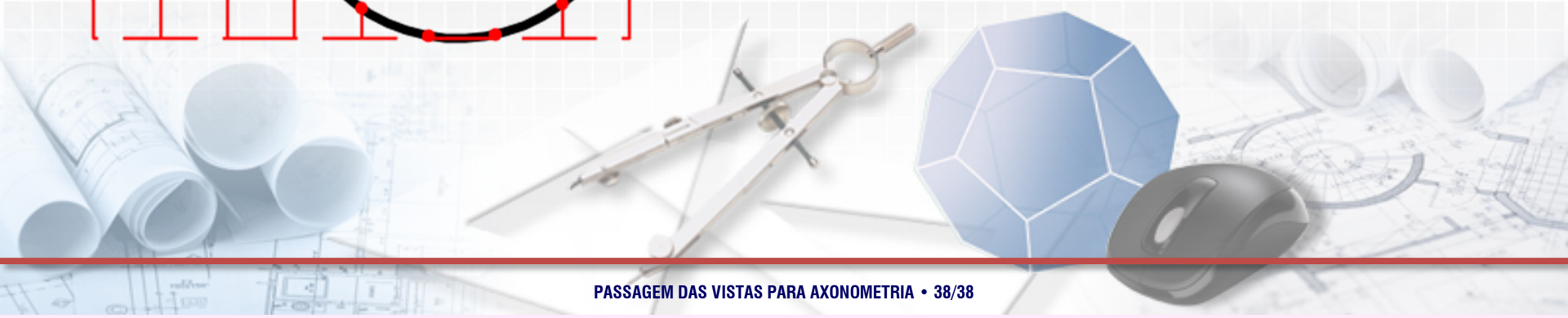
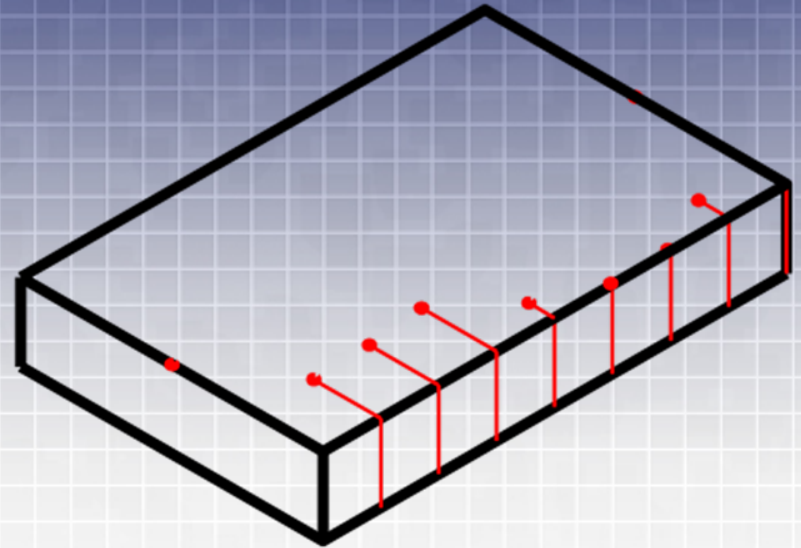
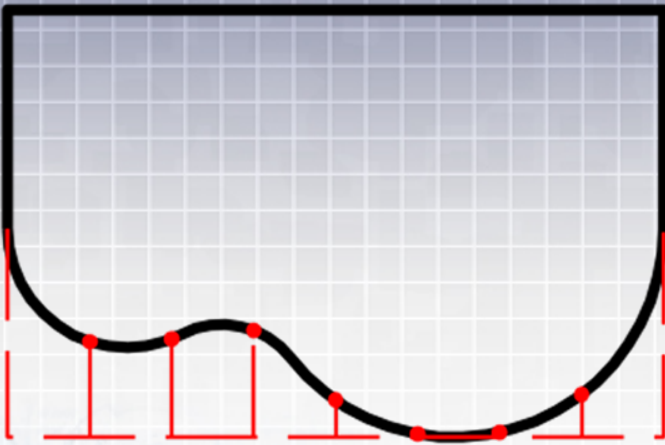

CURVAS IRREGULARES EM AXONOMETRIA

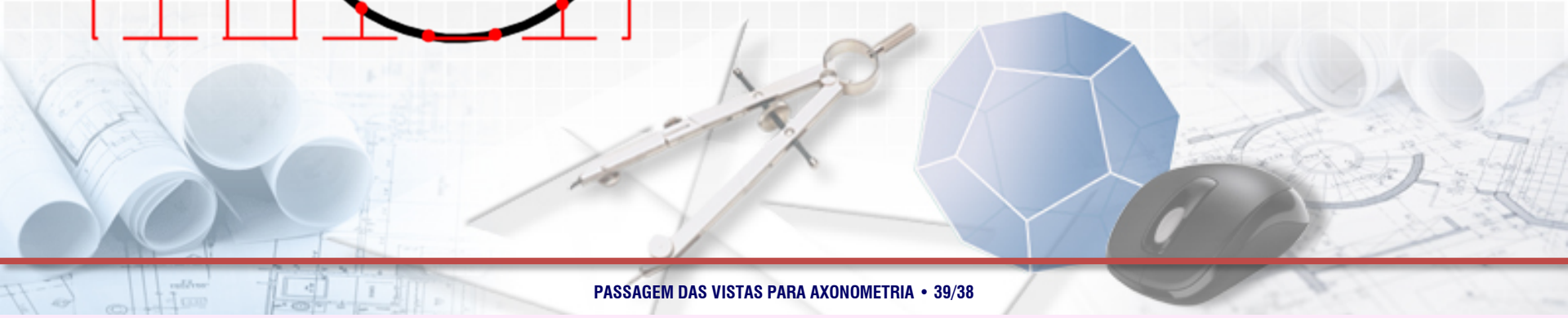
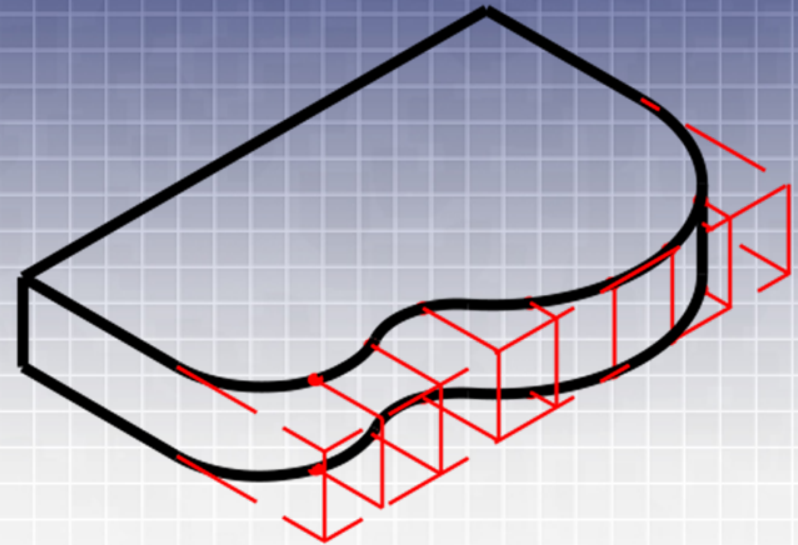
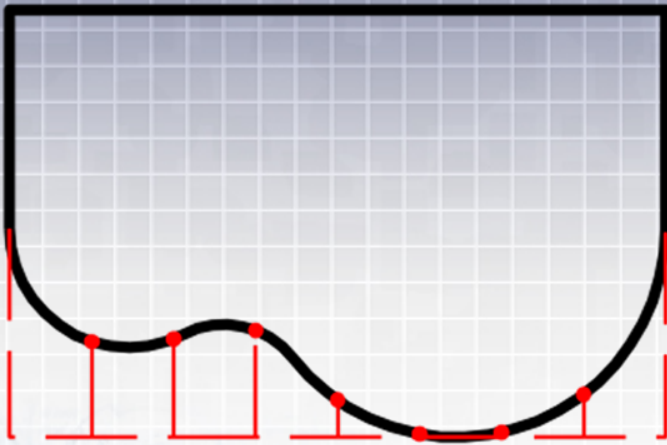

CURVAS IRREGULARES EM AXONOMETRIA

